

ISWITCH 402UC-L

4 x 2 Conference Presentation Switcher

User Manual V1.0



Contents

Important Safety Instructions	2
1. Introduction	3
1.1 Overview.....	3
1.2 Features.....	4
1.3 Package Contents	5
1.4 Specifications.....	5
2. Panel Overview	7
2.1 Front Panel	7
2.2 Rear Panel.....	9
3. Installation	9
4. Typical Applications	10
5. MST Mode.....	12
6. Charging Power Allocation for USB-C Inputs	13
7. Auto Switching	14
8. Button Control	14
9. RS232 Operation	15
9.1 Device Control	15
9.2 Control 3rd-party Device.....	16
9.3 TCP to RS232 routing.....	17
10. LAN Control.....	17
10.1 Obtain the IP Address of the Device	17
10.2 Telnet	18
10.3 Log in to the Web UI	18
10.4 Reset password and IP mode.....	19
10.5 Web UI.....	20
10.5.1 Switch.....	20
10.5.2 AV Setting	24
10.5.3 Control.....	28
10.5.4 Network.....	32
10.5.5 Diagnostics.....	37
10.5.6 System	38
10.5.7 Info	40

IMPORTANT SAFETY INSTRUCTIONS



1. Do not expose this apparatus to rain, moisture, dripping or splashing and that no objects filled with liquids, such as vases, shall be placed on the apparatus.



6. Clean this apparatus only with dry cloth.



2. Do not install or place this unit in a bookcase, built-in cabinet or in another confined space. Ensure the unit is well ventilated.



7. Unplug this apparatus during lightning storms or when unused for long periods of time.



3. To prevent risk of electric shock or fire hazard due to overheating, do not obstruct the unit's ventilation openings with newspapers, tablecloths, curtains, and similar items.

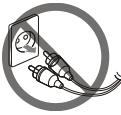

8. Protect the power cord from being walked on or pinched particularly at plugs.



4. Do not install near any heat sources such as radiators, heat registers, stoves, or other apparatus (including amplifiers) that produce heat.



9. Only use attachments / accessories specified by the manufacturer.



5. Do not place sources of naked flames, such as lighted candles, on the unit.



10. Refer all servicing to qualified service personnel.

1. INTRODUCTION

1.1 OVERVIEW

The **iSwitch 402UC-L** 4x2 conference presentation switcher is specially designed for modern meeting room environments, offering multiple models and specifications to meet diverse user requirements. It supports 4x2 matrix switching and features dual full-featured USB-C inputs along with dual HDMI + USB 3.0 inputs, allowing seamless connection to multiple laptops or desktop computers.

The switcher includes 4 local USB 3.0 device ports, enabling direct connection to a variety of USB conferencing devices such as USB cameras, audio bars, and USB speakers, making it ideal for comprehensive conference setups.

In terms of audio, the device supports flexible configuration options. HDMI and USB audio can be output via a local balanced audio output port, providing compatibility with various professional audio systems.

The presentation switcher is equipped with multiple control interfaces, including RS232, GPIO, RELAY, and sensor ports, allowing smooth integration with external control systems. It offers robust network functionality with two independent RJ-45 ports and supports USB-to-Ethernet conversion. Through VLAN segmentation and 802.1x authentication, the switcher ensures secure separation between presentation and USB networks.

It also supports various switching modes, including automatic switching, manual switching, and configurable priority switching. Additional features include support for HTTP/HTTPS configuration, 802.1x security, CEC and RS232 control, customizable GPIO functions, and a built-in Web UI and API for remote

management and system integration.

1.2 FEATURES

- 4x2 conference presentation switcher integrating video, audio, USB, control, and Ethernet functionality.
- Inputs and outputs support resolutions up to 5120x2160@30Hz and 5120x1440@60Hz.
- Equipped with dual USB-C and dual HDMI + USB 3.2 inputs; all ports support secure cable lock connections.
- Full-featured USB-C inputs support 5120x2160@30Hz and 5120x1440@60Hz video, USB 3.2 data, USB-to-Ethernet bridging, and up to 100W charging.
- One USB-C input supports MST (Multi-Stream Transport) for dual-screen conferencing scenarios.
- Supports various switching modes, including automatic switching, USB/video independent switching, and priority-based switching.
- Offers 4 USB 3.2 device ports for connecting conference peripherals such as cameras, speakerphones, and audio devices.
- Provides one balanced audio output for external audio systems; supports audio de-embedding and UAC (USB Audio Class).
- Includes RS232, GPIO, RELAY, and OCS sensor ports for integration with control systems and automation devices.
- Includes a dedicated USB charging port on the conference table interface to power mobile devices.
- Each input port features an independent USB-to-Ethernet bridge, enabling 1Gbps Ethernet connectivity for connected computers.
- Features two independent RJ-45 ports for Ethernet switching or VLAN configuration.
- Supports Ethernet-based control via HTTP and HTTPS, with 802.1x network authentication support.

1.3 PACKAGE CONTENTS

- 1 x **iSwitch 402UC-L** Matrix Switcher
- 1 x DC 20V/10A Power Adapter
- 1 x AC Power Cord with EU Pins
- 2 x USB 3.2 Type-C to Type-C Cable (L = 2m)
- 2 x USB 3.0 Type-A to Type-B Cable (L = 1.8m)
- 1 x 3.5mm 3-Pin Phoenix Male Connector
- 2 x 3.5mm 3-Pin Phoenix Male Connector (Double Layer)
- 1 x 3.5mm 5-Pin Phoenix Male Connector
- 1 x 3.5mm 6-Pin Phoenix Male Connector
- 4 x Mounting Brackets (with Screws)

1.4 SPECIFICATIONS

Technical	
Input/Output Port	2 x HDMI IN, 2 x USB-C IN, 2 x HDMI OUT, 2 x USB HOST (USB Type-B), 1 x AUDIO OUT (3.5mm, 5-pin phoenix connector), 4 x USB DEVICE (USB Type-A), 2 x RS232, 1 x GPIO (3.5mm, 6-pin phoenix connector), 2 x RELAY, 1 x SENSOR, 2 x ETHERNET (RJ45), 1 x DC 20V
Input/Output Signal Type	Supports HDMI with 5K Ultrawide Resolutions (5120x2160@30Hz) and 5K Super-wide Resolutions (5120x1440@60Hz). Supports HDCP 2.2/1.4.
USB HOST IN 1 & 2	Supports USB 3.2 Gen 2x1 standard, up to 10Gbit/s
USB-C IN 3&4	<p>USB-C IN 3: USB-C supports USB 3.2 Gen 2x1 standard, and supports:</p> <ul style="list-style-type: none"> • Video: DP alt mode, SST only, up to 5120x2160@30Hz and 5120x1440@60Hz. • USB data: Up to 10Gbit/s. • Charging: 100W. <p>USB-C IN 4: USB-C supports USB 3.2 Gen 2x1 standard, and supports:</p> <ul style="list-style-type: none"> • Video: DP alt mode, MST dual output, up to 5120x2160@30Hz and 5120x1440@60Hz • USB data: Up to 10Gbit/s. • Charging: 100W. <p> Note: The charging power of USB-C IN 3 and USB-C IN 4 supports the following allocation modes:</p>

Technical	
	<ul style="list-style-type: none"> • Dynamic Allocation; • 100W (USB IN 1) + 45W (USB-C IN 2); • 45W (USB IN 1) + 100W (USB-C IN 2); • 60W + 60W. Refer to " Charging Power Allocation for USB-C Inputs " section to get detail information.
USB DEVICE	Maximum supports USB 3.2 Gen 2x1 standard, up to 10Gbit/s. 5V/1.5A output per port.
Input/Output Resolution Supported	VESA: 800 x 600 ⁶ , 1024 x 768 ⁶ , 1280 x 768 ⁶ , 1280 x 800 ⁶ , 1280 x 960 ⁶ , 1280 x 1024 ⁶ , 1360 x 768 ⁶ , 1366 x 768 ⁶ , 1440 x 900 ⁶ , 1600 x 900 ⁶ , 1600 x 1200 ⁶ , 1680 x 1050 ⁶ , 1920 x 1200 ⁶ , 2048 x 1152 ⁶ , 2560 x 1440 ⁶ , 3440 x 1440 ⁶ , 5120x1440 ^{3,6} , 5120x2160 ³ CTA: 1280x720P ^{5,6} , 1920x1080P ^{1,2,3,4,5,6} , 3840x2160P ^{1,2,3,4,5,6} , 4096x2160P ^{1,2,3,4,5,6} , 5120x1440 ⁶ , 5120x2160 ^{3,6 (4:2:0)} 1 = at 24 (23.98) Hz, 2 = at 25 Hz, 3 = at 30 (29.97) Hz, 4 = at 48 Hz, 5 = at 50 Hz, 6 = 60 (59.94) Hz
HDR	All HDR formats, including HDR 10, HLG, HDR 10+ and Dolby Vision
Audio Format	<ul style="list-style-type: none"> • USB-C IN/HDMI IN/ HDMI OUT: Up to 7.1ch, including PCM 2.0/5.1/7.1ch, Dolby Digital, Dolby Digital Plus, Dolby TrueHD, Dolby Atmos, DTS 5.1, DTS-HD Master Audio and DTS:X. • Audio de-embedding: Stereo only.
ETHERNET	1000M/100M adaptive network
Maximum Data Rate	USB-C IN: 10Gbit/s (per lane) HDMI: 18Gbps USB 3.2: 10Gbit/s
Control Method	Front Panel Buttons, RS232, LAN (Telnet &Web UI)

General	
Operating Temperature	0°C to 45°C (32°F to 113°F)
Storage Temperature	-20°C to 70°C (-4°F to 158°F)
Humidity	10% to 90%, non-condensing
ESD Protection	Human-body Model: ±8kV (Air-gap discharge)/ ±4kV (Contact discharge)
Power Supply	DC 20V/10A
Power Consumption (Maximum)	180.6W (with 22.5W USB-A and 100W+45W USB-C charging) = 616.2 BTU/hr
Device Dimension (W x H x D)	300mm x 25mm x 180.2mm/11.81" x 0.98" x 7.09"
Product Weight	1.45kg/3.20lbs

Transmission Distance

Cable Type	Range	Supported Video
USB Type-C to USB Type-C Cable (USB 3.2 Gen 2, 10Gbps per lane)	2m/7ft	1080P@60Hz 24bpp 4K@30Hz 4:4:4 24bpp 4K@60Hz 4:2:0 24bpp 4K@60Hz 4:4:4 24bpp
HDMI	Input/Output: 10m/33ft	1080P@60Hz 24bpp 4K@30Hz 4:4:4 24bpp 4K@60Hz 4:2:0 24bpp
	Input/Output: 5m/16ft	4K@60Hz 4:4:4 24bpp

2. PANEL OVERVIEW

2.1 FRONT PANEL

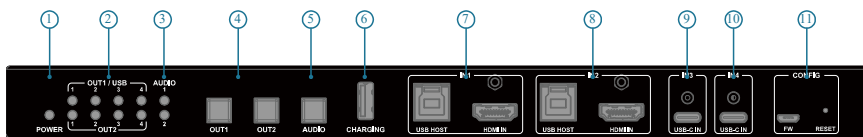

#	Name	Description
1	POWER LED	<ul style="list-style-type: none"> On: The device is powered on. Off: The device is powered off.
2	OUTPUT 1 / USB LEDs and OUTPUT 2 LEDs	<ul style="list-style-type: none"> Red: USB devices are connected to the corresponding USB host. Green: The corresponding video input is selected or the corresponding video input and USB host are selected. Off: The corresponding input are not selected.
3	AUDIO 1&2 LEDs	<ul style="list-style-type: none"> On: The corresponding de-embedded audio from HDMI OUT 1/2 is selected as source. Off: The corresponding de-embedded audio from HDMI OUT 1/2 is not selected as source for AUDIO OUT.
4	OUTPUT 1&2 Selection Button	Press the button to select input source for HDMI OUT 1/2.

#	Name	Description
5	AUDIO OUT Selection Button	Press the button to switch the audio source between the de-embedded audio from HDMI OUT 1 and HDMI OUT 2 for AUDIO OUT port.
6	CHARGING	USB 2.0 Type-A port. 5V/2A USB charging.
7 & 8	IN 1 & IN 2	<p>HDMI IN: Connect to HDMI sources.</p> <p>USB HOST: USB 3.2 type-B ports. Connect to USB HOST devices.</p> <p>Note:</p> <ul style="list-style-type: none"> • USB HOST ports in IN 1 and IN 2 groups are bound with HDMI IN ports in IN 1 and IN 2 respectively. For example, when select HDMI IN in IN 1 group as input source, all USB devices will be routed to the USB HOST in IN 1 group. • Both USB HOST ports support USB-to-Ethernet bridging, allowing laptops connected to these ports to access the network through the device's ETHERNET ports. The two USB HOST ports and the two USB Type-C ports share a 1Gbps Ethernet connection.
9 & 10	INPUT 3&4 (USB-C IN)	<p>USB 3.2 type-C ports. Connect to USB-C sources. The two full-featured USB-C ports support the following three functions:</p> <ul style="list-style-type: none"> • Supports audio, video and USB signal transmission, maximum 10Gbit/s data rate. <ul style="list-style-type: none"> ○ USB-C IN 3 and 4 support DP SST, one video output with 5K/4K signal transmission; ○ USB-C IN 4 supports DP MST, two video outputs with 5K/4K signal of each channel transmission. • Supports PD 3.0, and can supply up to 60W power for the connected device; • Supports 1G network connection, the laptop connected with these ports can access the Ethernet the matrix connected; <p>The following cable are recommended to use: USB Type-C to Type-C cable (USB 3.2 Gen 1x1 or above)</p> <p>Note: Refer to “Charging Power Allocation for USB-C Inputs” section to get detail charging power allocation for the two USB-C inputs.</p>
11	FW	<p>FW: Micro-USB port. For ARM firmware upgrade.</p> <p>RESET: Insert a tool such as a needle.</p> <ul style="list-style-type: none"> • Press and hold it for about 5s: Reset the IP settings, including reset the IP mode to DHCP, and reset the login password to “admin”. • Press and hold it for about 15s: Reset the device

#	Name	Description
		to factory defaults.

2.2 REAR PANEL

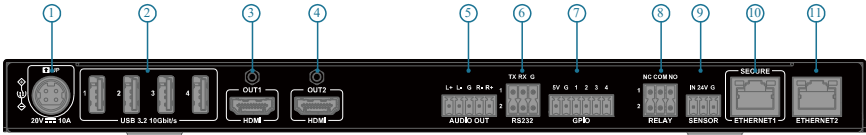

#	Name	Description
1	20V/10A	Connect to the power adapter provided.
2	USB DEVICE	USB 3.2 type-A ports, 5V/1.5A output per port. Connect to USB devices such as camera and speakerphone.
3 & 4	HDMI OUT (1~2)	Connect to the HDMI display devices.
5	AUDIO OUT	Connect to an audio receiver.
6	RS232 1 & 2	<ul style="list-style-type: none"> RS232 1: Connect to a RS232 control device for API control or connect to a 3rd party device for RS232 routing. RS232 2: Connect to a RS232 3rd party device for RS232 routing.
7	GPIO	Connect to GPIO devices. The device supports connecting to 6 GPIO devices.
8	RELAY 1 & 2	Connect to relay devices for relay control.
9	SENSOR	Connect to OCS sensor.
10 & 11	ETHERNET 1 (SECURE) & 2	Connect to a network device (e.g., network switch, router, computer, etc.) for LAN control (Web UI & Telnet). VLAN function can be configured via API commands and web UI, please refer to the separate document “API Command Set_iSwitch 402UC-L” or “ Network ” part in “Web UI” section.

3. INSTALLATION

Note: Before installation, ensure the device is disconnected from the power source.

1. Attach the bracket to one side of the enclosure using the screws provided. The bracket is attached to the enclosure as shown.

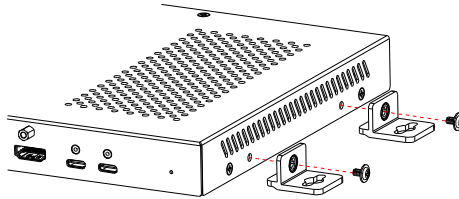

2. Repeat step 1 for the other side of the enclosure.
3. Attach the brackets to the surface or location desired using screws (not included in the package).

4. TYPICAL APPLICATIONS

Note:

- Before wiring, disconnect the power from all devices.
- During wiring, connect and disconnect the cables gently.

Note: By default, USB-C IN 4 is in DP SST mode, use the command “SET USBC4_DM MST<CR><LF>” or refer to web UI page (see the separate document “*API Command Set_ iSwitch 402UC-L*” or refer to [“Switch”](#) part in “Web UI” section) to set the USB-C IN 4 to MST mode. In this mode, the USB-C IN 3 is disabled, and the USB-C IN 4’s source can transmit two video signals with 4K each to the two HDMI outputs respectively.

1. 4x2 Presentation Switch with Dual Screen Mode

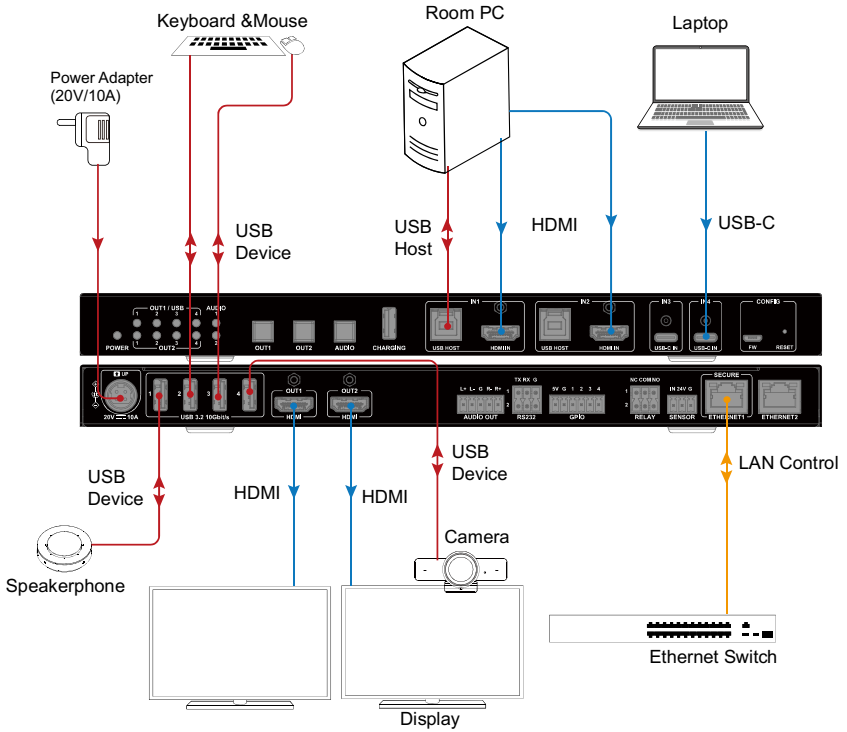

2. 4x2 Presentation Switch with Matrix Mode

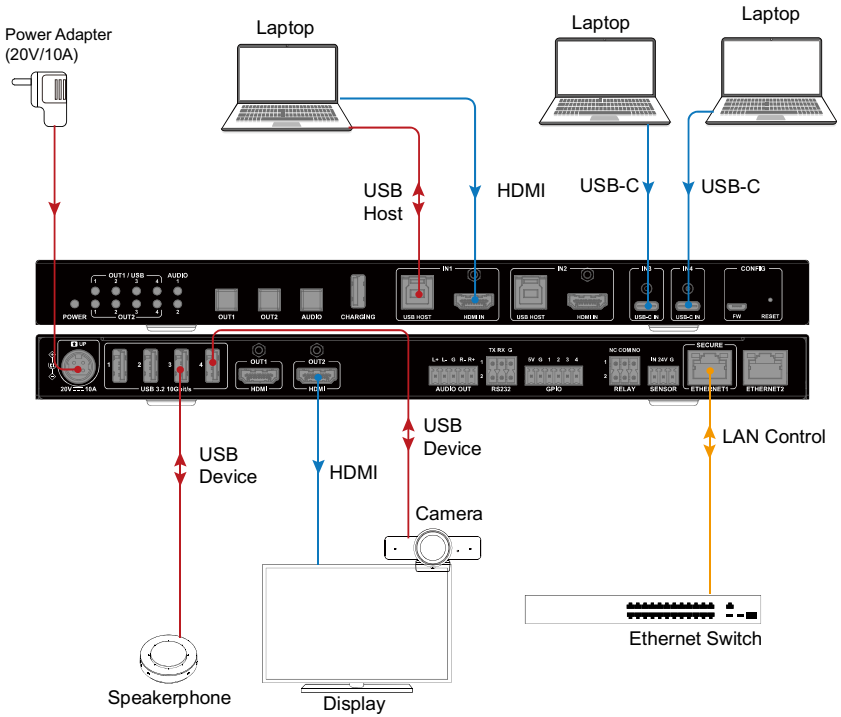

5. MST MODE

MST (Multi-Stream Transport) is a feature of the DisplayPort (DP) protocol that enables multiple video streams to be transmitted over a single DP interface. These streams can then be decoded and displayed on separate monitors by MST-capable devices.

Since USB-C natively supports DP Alt Mode, MST functionality can also be enabled via a USB-C interface.

The USB-C IN 4 port on the matrix supports MST mode (disabled by default) and can be enabled through the Web UI or API. Once MST mode is enabled, USB-C IN 4 can extend two independent desktop displays from one laptop to two output

ports simultaneously.

Note: Enabling MST mode occupies an additional input port, users must select to disable either the USB-C IN 3 or HDMI IN 2 input.

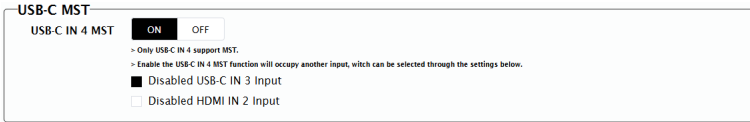

6. CHARGING POWER ALLOCATION FOR USB-C INPUTS

The charging power of USB-C IN 3 and USB-C IN 4 supports the following allocation modes:

- Dynamic Allocation;
- 100W (USB IN 3) + 45W (USB-C IN 4);
- 45W (USB IN 3) + 100W (USB-C IN 4);
- 60W + 60W.

Dynamic power allocation means that the charging power of the two USB-C ports is allocated based on the number of connected USB-C input laptops. The detailed requirements are as follows:

- When only one USB-C IN is connected, 100 W charging is supported.
- When two USB-C IN ports are connected, each port supports 60 W charging (60 W + 60 W).
- If the USB-C IN 3 is connected and configured for 100 W charging, and then a USB-C IN 4 is connected, the system must notify the first connected laptop to dynamically reduce the charging power to 60 W:
 - If the first laptop accepts the power reduction, the charging power of the USB-C IN 3 is reduced to 60 W, and the USB-C IN 4 port is notified that 60 W charging is available.

- If the first laptop does not accept the power reduction, the USB-C IN 4 port is notified that the maximum supported charging power is 45 W.

In the remaining modes, USB-C IN 3 and USB-C IN 4 are configured with fixed charging power values.

The charging power allocation for the two USB-C inputs can be configured via the Web UI or API (detail information, please refer to “[Control](#)” section or the separate document “*API Command Set_ iSwitch 402UC-L*”).

7. AUTO SWITCHING

The device supports automatic switching (HDMI and USB-C video and USB) and provides two modes:

- **LIFO mode.**
- **Priority mode.**

This function can be enabled/disabled through Web UI or API Commands.

Note:

1. Please refer to “[Switch](#)” part in the “Web UI” section or separate document “*API Command Set_ iSwitch 402UC-L*” to get detailed configuration information.
2. Video switching to detect valid signals, and USB switching to detect VBUS.

8. BUTTON CONTROL

Users can perform basic switching of input sources to outputs and audio source selection.

- **OUT 1** button: Press the button continuously to switch the input source for **HDMI 1** output. The LED will light when the corresponding source is selected.

 **Note:** The default mode of the USB switch is “**Follow video out 1**”, using

the “**OUT 1**” button will switch the video out 1 and the USB device at the same time.

- **OUT 2** button: Press the button continuously to switch the input source for output 2. The LED will light when the corresponding source is selected.
- **AUDIO** button: Select the audio de-embedding from which output, **OUT 1** or **OUT 2**. The LED will light when the corresponding audio source is selected.

 **Note:** Audio routing can be set via the Web UI and API, refer to the separate document “*API Command Set_ iSwitch 402UC-L*” or “**Audio Routing**” part in “Web UI” section for details.

9. RS232 OPERATION

The device provides two RS232 ports for device control or control of 3rd-party devices.

Supported functions are as follows:

- **RS232-1:**
 - Device control (API).
 - Control 3rd-party device.
 - TCP to RS232 routing.
- **RS232-2:**
 - Control 3rd-party device.
 - TCP to RS232 routing.

9.1 DEVICE CONTROL

Users may need to control the device via API commands. Connect an RS232-enabled device (such as a PC) to the **RS232-1** port. For detailed command information, please refer to the separate document “*API Command Set_ iSwitch 402UC-L*”). Before sending API commands to control the device, ensure the serial ports between this device and the PC are configured correctly. A

professional RS232 serial interface software (e.g., Serial Assist) may be needed as well.

Parameters	Default Value
Baud Rate	115200 bps
Data bits	8 bits
Parity	None
Stop bits	1 bit
Flow control	None

9.2 CONTROL 3RD-PARTY DEVICE

Advanced users may need to control the 3rd-party device perform automated operations, such as automatically turning the projector on/off. The device provides "**RS232 automatic/manual control**".

RS232 automatic/manual control

RS232 control is performed by pre-stored instructions in the device. When the trigger condition is met, the configuration command is automatically sent out through the RS232 port.

Users can store the following instructions in settings:

- Display ON/OFF.
- Volume MUTE/UNMUTE.
- Volume UP/DOWN.

Users can set these instructions through the Web UI or API and turn on the **Auto-RS232** function to automatically execute, or perform these operations by manually sending APIs.

Auto-RS232 conditions:

- **Display ON:** When any active source is connected to the device.
- **Display OFF:** When all sources are disconnected from the device and after the "**Delay Time**" set.

Please refer to the "RS232" part in the "Web UI" section or separate document "API Command Set_ iSwitch 402UC-L" to get detail command information.

9.3 TCP TO RS232 ROUTING

The TCP to RS232 routing function provides a tunnel from the network to the RS232 port, which can bypass the network control commands to the RS232 port. This function makes it easier for third-party devices such as a central-control device to control other devices connected to MS0402-N008.

TCP port number:

- **RS232-1:** 5000;
- **RS232-2:** 5001.

10. LAN CONTROL

10.1 OBTAIN THE IP ADDRESS OF THE DEVICE

The default IP mode of the device is: **DHCP**.

The user can obtain an IP address in the following ways:

1. Send API command via RS232-1 port.

Send API command "**GET IPADDR<CR><LF>**" to get the IP address, for example:

Input:

```
GET IPADDR<CR><LF>
```

Response:

```
IPADDR 172.16.18.173 MASK 255.255.255.0 GATEWAY  
172.16.18.1
```

2. Use the tool "SmartSetGUI" to search the IP address.
3. Check the IP address in the DHCP server.

10.2 TELNET

Telnet port: 23.

10.3 LOG IN TO THE WEB UI

The Web UI designed for this device allows for basic controls and settings. It can be accessed through a modern browser with latest version, e.g., Chrome, Safari, Firefox, IE10+, etc.

To get access the Web UI:

1. Connect one of the two ETHERNET ports of the device to a local area network. (Ensure there's a DHCP server in the network so that the device can obtain a valid IP address.)
Note: When VLAN is set to "Separate", please connect **ETHERNET-1** to the local area network for web UI control.
2. Connect the PC to the same network.
3. Input the device's IP address in the browser and press Enter, the following window will pop up. (Refer to [Obtain IP Address of the Device](#) section to get the device's IP address quickly).
4. The following window pops up. Input the password (default password: **admin**) and click "Login".



iSwitch 402UC-L

Password

Login

5. Input a new password in the dialog box and click “Apply” to enter the main page. The password must be 4 to 16 characters long, alphanumeric, and include at least one uppercase letter, one lowercase letter, and one number.

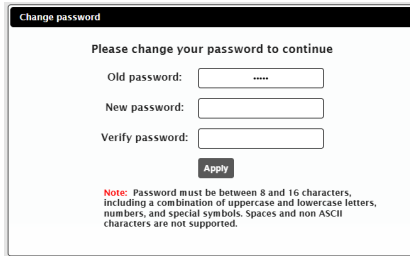

A dialog box titled "Change password" with a black header. The main text reads "Please change your password to continue". Below this are three input fields: "Old password:" with a masked password ".....", "New password:", and "Verify password:". An "Apply" button is located below the fields. A red note at the bottom states: "Note: Password must be between 8 and 16 characters, including a combination of uppercase and lowercase letters, numbers, and special symbols. Spaces and non ASCII characters are not supported."

Click the box it will display the password requirements.

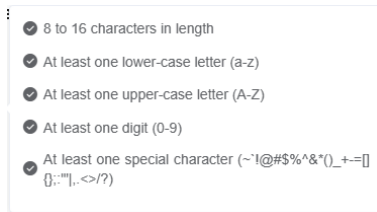

A list of password requirements, each preceded by a grey checkmark in a circle:

- 8 to 16 characters in length
- At least one lower-case letter (a-z)
- At least one upper-case letter (A-Z)
- At least one digit (0-9)
- At least one special character (~!@#\$%^&*()_+=[\];:~!.,<.>/?)

As the new password meets each requirement, the corresponding checkmark preceding that requirement turns black. When all checkmarks appear black, it indicates that the new password meets all requirements.

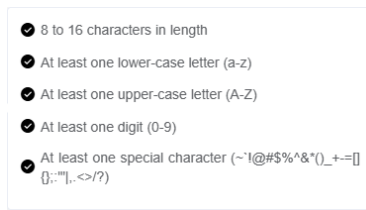

A list of password requirements, each preceded by a black checkmark in a circle:

- 8 to 16 characters in length
- At least one lower-case letter (a-z)
- At least one upper-case letter (A-Z)
- At least one digit (0-9)
- At least one special character (~!@#\$%^&*()_+=[\];:~!.,<.>/?)

10.4 RESET PASSWORD AND IP MODE

If users forget the login password, the following ways can be used to restore the default password:

- Hold the “**RESET**” hole on the front panel for about 5s to reset the IP mode to DHCP and login password to “admin”.
- Hold the “**RESET**” hole on the front panel for about 15s to reset the device to factory defaults, which includes resetting the password.
- Send the API command “**RESET**<CR><LF>” to reset the device to factory defaults, which includes resetting the password.

10.5 WEB UI

infobit iSwitch 402UC-L Web: V1.0.6

Switch AV Setting Control Network Diagnostics System Info

Video & USB

IN		IN 1 (HDMI)	IN 2 (HDMI)	IN 3 (USB-C)	IN 4 (USB-C)
OUT					
VIDEO OUT 1					
VIDEO OUT 2					
ALL					

USB Mode:

IN		IN 1 (USB-B)	IN 2 (USB-B)	IN 3 (USB-C)	IN 4 (USB-C)
OUT					
USB DEVICE					

Audio

FROM		USB HOST	AUDIO DE EMBED (VIDEO OUT 1)	AUDIO DE EMBED (VIDEO OUT 2)
TO				

10.5.1 Switch

1. Video & USB

Video & USB

OUT \ IN	IN	IN 1 (HDMI)	IN 2 (HDMI)	IN 3 (USB-C)	IN 4 (USB-C)
VIDEO OUT 1					
VIDEO OUT 2					
ALL					

USB Mode:

OUT \ IN	IN	IN 1 (USB-B)	IN 2 (USB-B)	IN 3 (USB-C)	IN 4 (USB-C)
USB DEVICE					

This section allows users to switch video/USB input for output, and set USB mode.

- **VIDEO OUT 1/2:** Click the button in the table to switch one input source for VIDEO OUT 1 / VIDEO OUT 2 (button turns from white to green when the selection is done).
- **ALL:** Click to select one input for all Video outputs (button turns from white to green when the operation is done).
- **USB Mode:** Click to select USB-A devices switching mode (Follow VIDEO OUT 1, Follow VIDEO OUT 2, and Independently), and click “Apply” to take effect.

Default setting: Follow VIDEO OUT1, the USB-A devices switching follows the VIDEO OUT 1 switching.

When set USB Mode to “Independent”, users can manually switch the USB host for the USB devices to be connected to by clicking the corresponding button in the table

USB Mode:

OUT \ IN	IN	IN 1 (USB-B)	IN 2 (USB-B)	IN 3 (USB-C)	IN 4 (USB-C)
USB DEVICE					

2. Audio

Audio

FROM \ TO	USB HOST	AUDIO DE-EMBED (VIDEO OUT 1)	AUDIO DE-EMBED (VIDEO OUT 2)
AUDIO OUT			

Audio Mute All:

HDMI OUT 1: HDMI OUT 2:

ANALOG OUT:

This section allows users to switch audio input to output.

- **AUDIO OUT:** Three audio sources can be selected. Default Setting: AUDIO DE-EMBED (VIDEO OUT 1).
 - **Audio Mute (ON/OFF):** Click to set the corresponding audio output to mute/unmute.
- All:** Click to set all audio to mute/unmute.
Default Setting: Unmute.

3. USB MST

USB-C MST

USB-C IN 4 MST

> Only USB-C IN 4 support MST.
> Enable the USB-C IN 4 MST function will occupy another input, which can be selected through the settings below.

Disabled USB-C IN 3 Input
 Disabled HDMI IN 2 Input

This section allows users to enable the **USB-C IN4 MST** function.

- **USB-C IN 4 MST:** Click to enable the MST function of USB-C IN 4 to ON/OFF. Default setting: OFF. When enabling this function, the USB-C IN 4 will occupy another input channel, check the box from the following inputs to set which input channel is occupied.

USB-C MST

USB-C IN 4 MST

> Only USB-C IN 4 support MST.
> Enable the USB-C IN 4 MST function will occupy another input, which can be selected through the settings below.

Disabled USB-C IN 3 Input
 Disabled HDMI IN 2 Input

4. Auto-Switch

Auto-Switching

Auto-Switch ON OFF

LIFO Mode
= Last in first out.

Priority Mode

Priority Setting

VIDEO OUT 1: USB-C IN 4 > USB-C IN 3 > HDMI IN 2 > HDMI IN 1

HDMI IN 1:	4	HDMI IN 2:	3	Apply
USB-C IN 3:	2	USB-C IN 4:	1	

VIDEO OUT 2: USB-C IN 4 > USB-C IN 3 > HDMI IN 2 > HDMI IN 1

HDMI IN 1:	4	HDMI IN 2:	3	Apply
USB-C IN 3:	2	USB-C IN 4:	1	

USB: USB-C IN 4 > USB-C IN 3 > USB-B IN 2 > USB-B IN 1

USB-B IN 1:	4	USB-B IN 2:	3	Apply
USB-C IN 3:	2	USB-C IN 4:	1	

Note: 1 - Highest priority 4 - Lowest priority 0 - Ignored

This section allows users to set the auto-switch function to ON/OFF, and select auto-switching mode.

Default: ON.

When the function is set to on, users can select auto switch mode between LIFO Mode and Priority Mode.

- **LIFO Mode (Default):** When inserting a new active input, all outputs will switch to this input automatically. When removing the current selected input, all outputs will switch to the previously active input.
- **Priority Mode:** When set to this mode, users can set input switching priority for **VIDEO OUT 1**, **VIDEO OUT 2** and **USB** from each zone.

Default priority for VIDEO OUT 1 / 2: USB IN 4 > USB IN 3 > HDMI IN 2 > HDMI IN 1.

Default priority for USB: USB-C IN 4 > USB-C IN 3 > USB-B IN 2 > USB-B IN 1.

Note:

- "1" indicates the highest priority, "4" indicates the lowest priority, and "0" means this port will be ignored in automatic switching.

■ Priority Mode

Priority Setting

VIDEO OUT 1: USB-C IN 4 > USB-C IN 3 > HDMI IN 2

HDMI IN 1:	<input type="text" value="0"/>	HDMI IN 2:	<input type="text" value="3"/>
USB-C IN 3:	<input type="text" value="2"/>	USB-C IN 4:	<input type="text" value="1"/>

Apply

- When two inputs are set to the same priority, for example,

■ Priority Mode

Priority Setting

VIDEO OUT 1: USB-C IN 4 > HDMI IN 1 > USB-C IN 3 > HDMI IN 2

HDMI IN 1:	<input type="text" value="1"/>	HDMI IN 2:	<input type="text" value="3"/>
USB-C IN 3:	<input type="text" value="2"/>	USB-C IN 4:	<input type="text" value="1"/>

Apply

It will follow the sequence of priority is **USB IN 4 > HDMI IN 1 > USB IN 3 > HDMI IN 2**.

- When the USB Switch mode is set to follow video out 1/2, it will follow the corresponding video output to switch.
- When the USB Switch mode is set to independently, USB device switching also follows LIFO mode, and can set priority.

10.5.2 AV Setting

1. Down-Scaler

Down-Scaler

Down-Scaler HDMI OUT 1: HDMI OUT 2:

This section allows users to set the down-scaler function for each output.

- **Down-Scaler:** Select the mode from the drop-down menu, and click “Apply” to take effect.
 - **Auto (Default):** Automatically convert 4K resolution to 1080P when connected to a 1080P display.
 - **Forced 1080P:** Forcely converts the input 4K resolution to 1080P regardless of the connected display's capabilities.
 - **OFF:** Disabled down-scaler function.

2. EDID

EDID

EDID Setting

HDMI IN 1: Fixed 4K@60Hz 2.0ch

HDMI IN 2: Fixed 4K@60Hz 2.0ch

USB-C IN 3: Fixed 4K@60Hz 2.0ch

USB-C IN 4: Fixed 4K@60Hz 2.0ch USB-C IN 4. (Secondary) Fixed 4K@60Hz 2.0ch

Custom EDID

EDID Read

This section allows users to set the EDID for each input and read the EDID of each output.

- **EDID Setting:** Select EDID for the input port, and click “Apply” to take effect.

The default setting for all inputs: Fixed 4K@60Hz 2.0ch.

EDID Values include:

Copy from the HDMI OUT 1;

Copy from the HDMI OUT 2;

Fixed 5120x2160@60Hz 2.0ch;

Fixed 5120x1440@60Hz 2.0ch;

Fixed 4K@60Hz 7.1ch;

Fixed 4K@60Hz 2.0ch;

Fixed 4K@30Hz 7.1ch;

Fixed 4K@30Hz 2.0ch;

Fixed 1080P@60Hz 7.1ch;

Fixed 1080P@60Hz 2.0ch;

Custom EDID 1;

Custom EDID 2.

- **Custom EDID:** Click “Upload” to enter the following page:

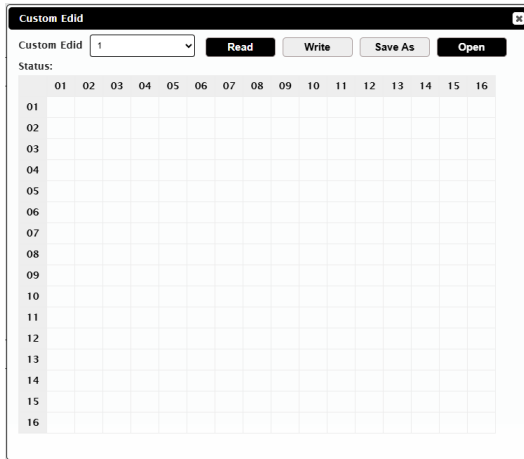

- **Custom EDID:** Select a customized EDID from the drop-down menu (1 or 2).
- **Read:** Click to read the selected customized EDID. The result is shown on the table of the page.
- **Write:** Click to write the opened EDID to the selected customized EDID space.
- **Save As:** Click to save the customized EDID to the local PC.
- **Open:** Click to select an EDID bin file from the local PC.
- **Status:** Shows the status of reading selected customized EDID.
- **EDID Read:** Read the EDID of the output port and save it. Click "Read" button to enter the following page:

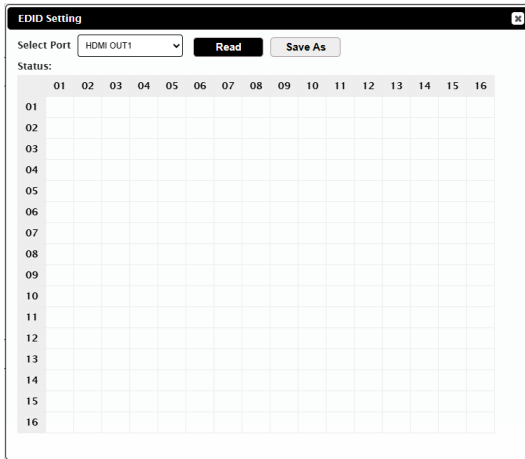

- **Select Port:** Select an output port from the drop-down menu.
- **Read:** Click to read the EDID of the selected output. The result is shown on the table of the page.
- **Save As:** Click to save the EDID as a bin file to the local PC.
- **Status:** Shows the status of reading EDID.

3. HDCP



This section allows users to enable/disable the HDCP capability of inputs.

Default setting: HDMI IN 1/2: ON; USB-C IN 3/4: OFF.

10.5.3 Control

1. CEC

The screenshot shows a control panel for CEC. At the top, there is a dropdown menu for 'CEC port' set to 'All Outputs', and two buttons: 'Display ON' and 'Display OFF'. Below this is the 'Auto-CEC' section with 'ON' and 'OFF' radio buttons, a 'Delay Time (sec):' input field set to '120', and an 'Apply' button. A note below states '> The delay time is only valid for the Display OFF command.' The 'CEC Command' section has two rows: 'Display ON:' with an input field containing '40 04' and buttons 'Save', 'Test', 'Reset'; and 'Display OFF:' with an input field containing '40 36' and buttons 'Save', 'Test', 'Reset'.

This section allows users to control the connected CEC-enabled displays to power on/off and set the **Auto-CEC** function.

- **CEC port:** Select the output port to control.
- **Display ON/OFF:** Click to control the corresponding CEC-enabled display to power on/off immediately.
- **Auto-CEC:** Enable/disable the auto-CEC function of the selected output. Default setting: ON.
- **Delay Time:** Delay time for CEC "Display OFF" command. When the CEC display-off conditions are met, the command will not be issued until the set time arrives. Default setting: 120s. Range: 30s~1800s.
- **CEC Command:** Input the display on/off command to control the corresponding display.
 - **Save:** Click to save the input command.
 - **Test:** Click to send the input command test the input command.
 - **Reset:** Click to reset the command to default value.

Note: Please get the commands from the display's manufacturer supplier or user manual.

2. RS232

This is an identical screenshot of the CEC control interface as described above, showing the same settings and layout.

This section allows users to set parameters for the RS232 port, set the **Auto-RS232** function and set the RS232 pre-stored command.

- **RS232 Port:** Select RS232 port to set from the drop-down menu.
- **Power ON/OFF:** Click to send the saved display on/off command to power on/off the 3rd device connected to the selected RS232 port.
- **Baud Rate:** Select the baud rate from the drop-down menu and click “Apply” to take effect. Default setting: 115200.
- **Auto-RS232:** Enable/disable the auto-RS232 function of the selected output. Default setting: ON.
- **Delay Time:** Delay time for RS232 “Power OFF” command. When the RS232 display-off conditions are met, the command will not be issued until the set time arrives. Default setting: 120s. Range: 30s~1800s.
- **RS232 Command:** Input the Display ON/OFF commands for the 3rd party device in the corresponding field. The serial commands for displays and projectors are provided by their manufacturer and can be found in the instructional documentation.
 - **String/HEX:** If the command for display on/off is only available in Hex format, check the “HEX” button and input the Hex command in the field, otherwise, check the “String” button.
 - **Save:** Click to save the input command to the matrix.
 - **Test:** Click to send the input command to the 3rd device directly to test it.

 **Note:** The RS232 command must be set before use, otherwise the RS232 port will not send anything.

3. RELAY

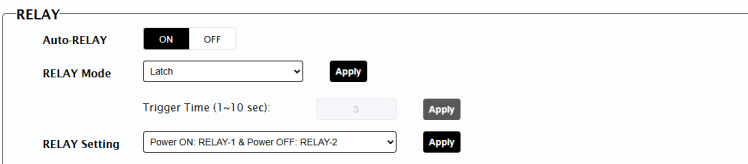

RELAY

Auto-RELAY ON OFF

RELAY Mode

Trigger Time (1~10 sec):

RELAY Setting

This section allows users to configure the RELAY.

- **Auto-RELAY:** Click to set auto-RELAY function to on/off. Default setting: ON.
When it is set to on, the relay automatically sends a power-on command when an input signal is detected, and a power-off command when no active signal is detected.
- **RELAY Mode:** Select relay mode from the drop-down menu (Latch or Momentary), and click “Apply” to take effect. Default setting: Latch.
 - **Latch:** Level mode.
 - **Momentary:** Pulse mode.
- **Trigger Time:** When setting relay mode to momentary, input the trigger time in this field, and click “Apply” to take effect. Default setting: 3s. Range: 1s~30s.
- **RELAY Setting:** Select relay setting mode from the drop down menu.
 - **POWER ON: RELAY-1; POWER OFF: RELAY-2** (default): When the automatic mode is triggered as Power On, the NC and COM pins of RELAY-1 are connected (relay closed). When the automatic mode is triggered as Power Off, the NC and COM pins of RELAY-2 are connected (relay closed).
 - **POWER ON: RELAY-2; POWER OFF: RELAY-1:** When the automatic mode is triggered as Power On, the NC and COM pins of RELAY-2 are connected. When the automatic mode is triggered as Power Off, the NC and COM pins of RELAY-1 are connected.
 - **POWER ON: RELAY-1&2; POWER OFF: RELAY-1&2:** When the automatic mode is triggered as Power On, the NC and COM pins of both RELAY-1 and RELAY-2 are connected. When the automatic mode is triggered as Power Off, the NC and COM pins of both RELAY-1 and RELAY-2 are connected.

4. SENSOR

SENSOR

24V Power ON OFF

I/O Status Low High

This section allows users to set 24V output voltage of the sensor to on/off and get I/O status.

- **24V Power:** Enabled/disable the 24V power out for the sensor port. Default setting: ON.
- **I/O Status:** Click “Get” to get the current I/O status of the sensor port.

5. USB Device Control



USB Device Control

Device Control VBUS Mode: Follow Host Apply

This section allows users to set VBUS mode for USB device ports.

VBUS Mode: Select VBUS mode.

- **Follow Host** (default): The USB Device Vbus follows the status of the USB Host Vbus: when the USB Host device is connected, the USB Device Vbus is high; when the USB Host is disconnected, the USB Device Vbus is low.
- **Always High:** The Vbus (5V) on the corresponding USB Device port is always enabled and remains powered on, regardless of the USB Host connection status.
- **Always Low:** The Vbus (5V) on the corresponding USB Device port is always disabled and no power is supplied to the connected USB device.

6. GPIO

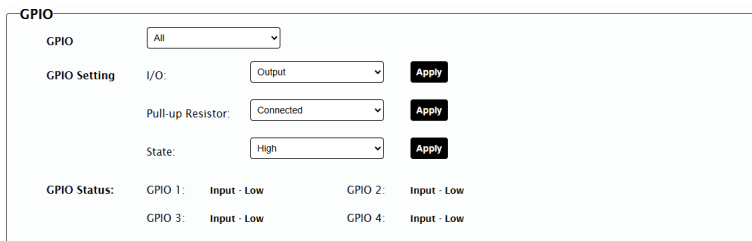

GPIO

GPIO All

GPIO Setting I/O: Output Apply

 Pull-up Resistor: Connected Apply

 State: High Apply

GPIO Status: GPIO 1: Input - Low GPIO 2: Input - Low

 GPIO 3: Input - Low GPIO 4: Input - Low

This section allows users to configure GPIO.

- **GPIO:** Select the GPIO port from the drop-down menu to configure.
- **GPIO Settings:**
 - **I/O:** Select the GPIO type between “Output” and “Input”, and click

“Apply” to take effect.

When select "Output":

- **Pull-up Resistor:** Enable/disable the Pull-up Resistor.
- **State:** Set GPIO output state to “High” or “Low”.

When select "Input":

GPIO

GPIO

GPIO Setting I/O:

GPIO Status: GPIO 1: Input - Low GPIO 2: Input - Low
GPIO 3: Input - Low GPIO 4: Input - Low

- **GPIO Status:** Shows the current GPIO type and status.

7. Charging Power Configuring

Charing Power Configuring

Power Mode Dynamic Allocation
 100W + 45W (IN 3 & IN 4)
 45W + 100W (IN 3 & IN 4)
 60W + 60W

This section allows users to configure the charging power.

Power Mode: Click the checkbox in front of the corresponding option to select the charging power configuration for USB IN 1 and USB IN 2.

Default setting: Dynamic Allocation.

10.5.4 Network

1. Network Setting

Network Setting

IP Type

IP Address

Subnet Mask

Default Gateway

Note: After changing network configuration, please reopen the web page with the new network settings.

The network is used to set the IP mode.

Note:

- When "Static" is selected, please ensure your PC is in the same network segment as the Matrix.
- Please wait for 2-3 minutes for the LAN module to reboot and reconnect after the network setting is changed.

2. Service Capability

Service Capability

Web Service	HTTP:	<input checked="" type="checkbox"/> ON	<input type="checkbox"/> OFF
	HTTPS:	<input checked="" type="checkbox"/> ON	<input type="checkbox"/> OFF

This section allows users to set HTTP and HTTPS.

- **HTTP:** Enable/disable the HTTP connection. Default Setting: ON.
- **HTTPS:** HTTPS is supported and CAN NOT disabled.

3. USB to Ethernet Bridge

USB to Ethernet Bridge

All:	<input checked="" type="checkbox"/> ON	<input type="checkbox"/> OFF		
USB-B IN 1:	<input checked="" type="checkbox"/> ON	<input type="checkbox"/> OFF	USB-B IN 2:	<input checked="" type="checkbox"/> ON <input type="checkbox"/> OFF
USB-C IN 3:	<input checked="" type="checkbox"/> ON	<input type="checkbox"/> OFF	USB-C IN 4:	<input checked="" type="checkbox"/> ON <input type="checkbox"/> OFF

USB Bridge refers to the USB Network Card.

The device provides four USB network cards on USB-C and USB-B ports.

This section allows users to enable/disable the USB bridge function for each port. Default setting: ON. When it is set to on, the device connected to the USB-B 1/2 or USB-C IN 3/4 can access to the network the ETHERNET ports connected.

4. VLAN Mode

VLAN Mode

VLAN Mode

> Transparent: Network interconnection of all devices.
> Separated: The secure network port (Ethernet 1) is only used to log in to the Web UI. Other networks are connected to Ethernet 2.

VLAN settings can help administrators isolate the internal network and the guest network to protect the network security.

The device provides **TWO** Ethernet ports, which can be used for VLAN settings.

- **VLAN Mode:** Select VLAN mode from the drop-down menu, and click “Apply” to take effect.
 - **Transparent:** Network interconnection of all devices.

VLAN Setting -- Transparent

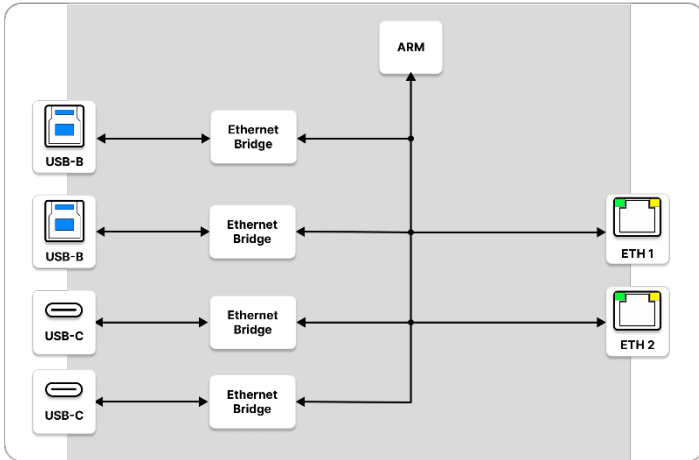

- **Separated:** Isolate the device network from the USB NIC network. Only the secure network port, **Ethernet 1**, can access the device's Web UI. Other USB NIC devices are connected to **Ethernet 2**.

VLAN Setting -- Separated

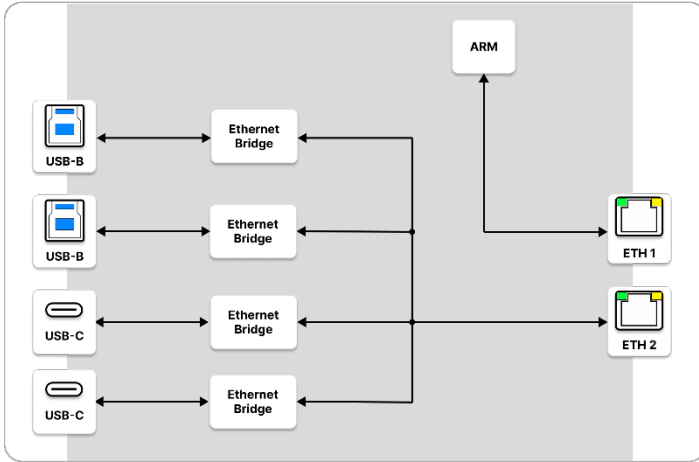

5. 802.1x

802.1x

802.1x ON OFF

Authentication Method: EAP-TLS

Username: *

Client Certificate:*

Private Key:*

Private Key Password:*

Serve Certificate: ON OFF

CA Certificate:*

Browse

Browse

Browse

Apply

- **802.1x:** Click to enable/disable 802.1x Authentication service. The device supports "EAP-TLS" and "EAP-MSCHAP V2" two mode. Default setting: OFF.

When set 802.1x to ON:

802.1x supports authentication based on port and MAC address.

The two following authentication methods are offered:

802.1x ON OFF

Authentication Method: EAP-TLS

Username: *

Client Certificate:*

Private Key:*

Private Key Password:*

Serve Certificate: ON OFF

CA Certificate:*

802.1x ON OFF

Authentication Method: EAP-MSCHAP V2

Username: *

Password:*

Serve Certificate: ON OFF

CA Certificate:*

- **EAP-TLS:** This method requires to submit username, CA certificate, Client Certificate, private key and private key password for authentication.
 - Username require alphanumeric, “-”, “_” and characters within length of 1 to 24 characters, “-“ and “_” cannot be at beginning or end.
 - Private Key Password require printable ASCII characters within length of 1 to 24 characters.
- **EAP-MSCHAP V2:** This method requires to submit username and password for authentication.
 - Username require alphanumeric, “-”, “_” and characters within length of 1 to 24 characters, “-“ and “_” cannot be at the beginning or end.
 - Password require printable ASCII characters within length of 1 to 24 characters.
- **Server Certificate:** Click to set server certificate to on/off. Default setting: OFF.
When it is set to on, users need to submit a CA certificate for authentication.
- **Apply:** Click to perform above settings and reboot the device.

10.5.5 Diagnostics

Date	Level	Event Type	Event Source	Details
<input type="text" value="Start Date"/> - <input type="text" value="End Date"/>	INFO	Filter	Filter	Filter details
2026-06-15 07:53:15+00:00	INFO	APP	USER	WEB client [192.168.4.209:62150] connected
2026-06-15 07:36:52+00:00	INFO	USBC	SYSTEM	IN.4@INPUT4 source cable disconnected
2026-06-15 07:36:52+00:00	INFO	USBC	SYSTEM	IN.3@INPUT3 source cable disconnected
2026-06-15 07:36:52+00:00	INFO	HDMI	SYSTEM	IN.2@INPUT2 source cable disconnected
2026-06-15 07:36:51+00:00	INFO	HDMI	SYSTEM	IN.1@INPUT1 source cable disconnected

Showing 46 events

Export Current Clear Current Export All

This section get events report information.

- **Auto Refresh:** By default, the information is refreshed automatically. If you want to retrieve the latest reported information manually, uncheck Auto Refresh and click the “ ” button to update and obtain the most recent data.
- **Date:** Click to set the start date and end date of the displayed report event information.
- **Level:** Select the displayed report event information level from the drop-down menu. Default setting: INFO.
- **Event Type:** Click to select displayed report event information type from the drop-down menu. No default value.
- **Event Source:** Click to select the event source from the user or system. No default value.

 **Note:** For the above three blank boxes, move the mouse to the icon “ ∨ ”, when the mouse cursor changes to a hand shape and an “ ⊕ ” icon appears, click this symbol to delete the selected level.

- **Details:** Input report event details to filter. When input detail information, click the icon “ ⊕ ” to delete it.
- **Export Current:** Click to export the current filtered event report information to local PC.
- **Clear Current:** Click to clear all event report information.

Spaces and non ASCII characters are not supported.

2. FW Update



FW Update

file:

Browse

Upgrade

- 1) Click “Browse” to select the update file from local PC.
- 2) Click “Upgrade” to start the upgrading.

Note: DO NOT power off the device during the updating process.

3. Configuration Import and Export



Configuration import and export

Export Settings Import Settings

- **Export Settings:** Click to export the settings file to the local PC.
- **Import Settings:** Click to import the settings file from the local PC and apply the imported settings.

4. Restore Factory



Restore Factory

Factory Default Reboot

- **Factory Default:** Click to set the device to factory defaults.
- **Reboot:** Click to reboot the device.

5. Version

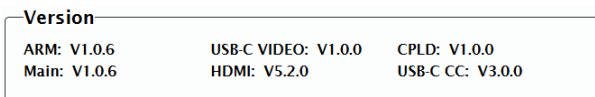

Version

ARM: V1.0.6	USB-C VIDEO: V1.0.0	CPLD: V1.0.0
Main: V1.0.6	HDMI: V5.2.0	USB-C CC: V3.0.0

This section shows the device's firmware version information.

6. Log

Log

Export Log

Note: Please wait a few moments for log retrieval.

```
16:09:11 Receive : CPLD 1.0.0
16:09:11 Receive : USB_C_CC 3.0.0
16:09:11 Receive : HDMI 5.2.0
16:09:11 Receive : USB_C_VIDEO 1.0.0
16:09:11 Receive : ARM 1.0.6
16:09:11 Receive : MAIN 1.0.6
16:09:11 Send : GET VER ALL
16:07:20 Send : [{"url":"api/v1/log/event","type":"request","id":1,"method":"post","body":{"limit":1,"op":"query"}]}
```

This section displays system setting change records.

Export Log: Click to download the log file to the local PC.

Note: Please wait for a few moments for log retrieval.

10.5.7 Info

1. INPUT STATUS

INPUT STATUS

Input1

Status: Disconnected

Video: N/A

Audio: N/A

HDCP: N/A

Input2

Status: Connected

Video: 3840x2160@60,RGB,8bit

Audio: Non-PCM

HDCP: NO HDCP

Input3

Status: Disconnected

Video: N/A

Audio: N/A

HDCP: N/A

Input4

Status: Disconnected

Video: N/A

Audio: N/A

HDCP: N/A

This section shows the connection status, video format, audio format and HDCP

status of input ports.

2. OUTPUT STATUS

OUTPUT STATUS

Output1

Status: Disconnected

Video: N/A

Audio: N/A

HDCP: N/A

Output2

Status: Outputting

Video: 1920x1080@60,RGB,8bit

Audio: Non-PCM

HDCP: NO HDCP

This section shows the connection status, video format, audio format and HDCP status of output ports.