

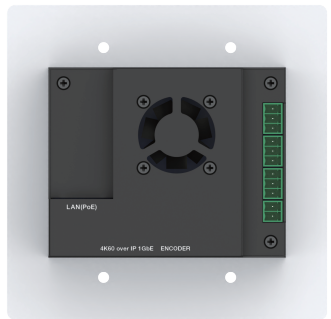

iSwitch 2000D-WPT

(US-2Gang version)

JPEG2000 4K60 AV over IP 1GbE
Encoder (Wall-plate) with KVM Function

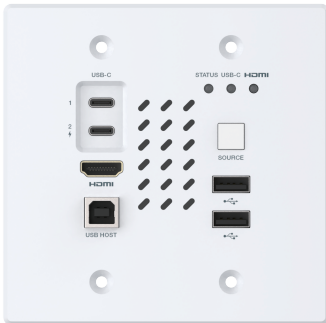

User Manual

VER 1.0

www.infobitav.com info@infobitav.com

Thank you for purchasing this product

For optimum performance and safety, please read these instructions carefully before connecting, operating or adjusting this product. Please keep this manual for future reference.

Surge protection device recommended

This product contains sensitive electrical components that may be damaged by electrical spikes, surges, electric shock, lighting strikes, etc. Use of surge protection systems is highly recommended in order to protect and extend the life of your equipment.

Table of Contents

| | |
|---|----|
| 1. Introduction..... | 1 |
| 2. Features..... | 1 |
| 3. Package Contents..... | 2 |
| 4. Specifications..... | 3 |
| 5. Operation Controls and Functions..... | 6 |
| 5.1 Encoder Panel..... | 6 |
| 5.2 Decoder Panel..... | 8 |
| 6. MJPEG Substream Operation Introduction..... | 10 |
| 6.1 MJPEG Substream Preview/Configuration via Web Page..... | 10 |
| 6.2 VLC Media Player Instruction..... | 14 |
| 7. Switch Model..... | 17 |
| 8. 4K over IP System Control..... | 17 |
| 9. Application Example..... | 18 |

1. Introduction

This 4K60 AV over IP 1GbE Encoder (Wall-plate) is based on JPEG2000 technology, and uses ASPEED AST1530 for image codec and low-latency KVM applications. It features HDMI and USB-C dual input, with a video resolution of up to 4K60 4:4:4. This product supports audio embedding and de-embedding function, as well as USB 2.0/KVM/Camera, 1G Ethernet, bi-directional RS-232 (pass-through & Guest mode) and PoE function. Guest mode controls of RS-232 and CEC are supported. Dante AV-A mode is supported if the product is license activated.

Built-in MJPEG Substream which supports plenty API commands to achieve flexible configurations is useful for 3rd party control Apps to preview video content.

The system is based on Linux for software development, provides flexible control methods, and can realize intelligent networking based on Gigabit Ethernet Switch.

2. Features

- ☆ HDCP 2.2 and DP 1.2 compliant
- ☆ Support 18Gbps video bandwidth
- ☆ Input and output video resolution is up to 4K60 4:4:4, as specified in HDMI 2.0b
- ☆ Signal transmission distance can be extended up to 328ft/100m via CAT6/6A/7 cable
- ☆ Transmit video, analog audio, RS-232, CEC and USB signal over Ethernet
- ☆ Support USB 2.0 and KVM function
- ☆ US 2-Gang wall-plate
- ☆ With HDMI and USB-C dual inputs, supporting auto switching (switch to the corresponding signal input channel automatically when the signal source is connected and detected) and manual switching modes
- ☆ The USB-C 1 port supports video/audio/USB data transmission and power charging to USB-C source device by USB-C adapter connected to the USB-C 2 port

- ☆ Audio embedding and de-embedding are supported
- ☆ Dante AV-A mode is supported if license activated
- ☆ Support unicast and multicast functions
- ☆ Support point-to-point, video matrix and video wall functions (video wall supports up to 9x9)
- ☆ Intelligent video wall class management
- ☆ Built-in MJPEG Substream for video real-time preview on portable devices
- ☆ Support 1G Ethernet Switch, router and hub devices transmission
- ☆ Standard PoE (802.3at PD device) or local 12V power supply
- ☆ Built-in web page configuration and control, Telnet and SSH as well
- ☆ Support HDR10, Dolby Vision, HLG bypass
- ☆ Audio formats: LPCM 2.0/5.1/7.1CH, Dolby Digital/Plus/EX, Dolby True HD, Dolby Atmos, DTS, DTS-96/24, DTS-EX DSD, DTS High Res, DTS-HD Master, DTS:X
- ☆ Flexible control via Web GUI/TCP/RS-232 and third-party central control
- ☆ Smart networking design for easy and flexible installation

3. Package Contents

- ① 1 x JPEG2000 4K60 AV over IP 1GbE Encoder Wall-plate
- ② 3 x 3pin-3.5mm Phoenix Connector (Male)
- ③ 1 x 12V/2.5A Multinational Power Supply (with 2pin-3.5mm Phoenix Connector)
- ④ 1 x User Manual

4. Specifications

| Technical | |
|----------------------------|---|
| HDMI Compliant | HDMI 2.0b |
| HDCP Compliant | HDCP 2.2 |
| Video Bandwidth | 18Gbps |
| USB Bandwidth | 480Mbps |
| Video Compression Standard | JPEG2000 |
| Video Network Bandwidth | 1G |
| Input Video Resolution | 640x480p60Hz, 800x600p60Hz, 1024x768p60Hz, 1280x1024p60Hz, 1360x768p60Hz, 1440x900p60Hz, 1440x1050p60Hz, 1600x1200p60Hz, 720x480i59.94Hz(480i59), 720x480p59.94Hz(480p59), 720x576i50Hz(576i50), 720x576p50Hz(576p50), 1280x720p50Hz (720p50), 1280x720p59.94Hz(720p59), 1280x720p60Hz(720p60), 1920x1080i50Hz(1080i50), 1920x1080i59.94Hz(1080i59), 1920x1080i60Hz(1080i60), 1920x1080p23.98Hz(1080p23), 1920x1080p24Hz(1080p24), 1920x1080p25Hz(1080p25), 1920x1080p29.97Hz(1080p29), 1920x1080p30Hz(1080p30), 1920x1080p50Hz(1080p50), 1920x1080p59.94Hz(1080p59), 1920x1080p60Hz(1080p60), 3840x2160p23.98Hz(2160p23), 3840x2160p24Hz(2160p24), 3840x2160p25Hz(2160p25), 3840x2160p29.97Hz(2160p29), 3840x2160p30Hz(2160p30), 3840x2160p50Hz(2160p50), 3840x2160p59.94Hz(2160p59), 3840x2160p60Hz(2160p60), 4096x2160p23.98Hz, 4096x2160p24Hz, 4096x2160p25Hz, 4096x2160p29.97Hz, 4096x2160p30Hz, 4096x2160p50Hz, 4096x2160p59.94Hz, 4096x2160p60Hz |
| Output Video Resolution | Depends on the optional decoder |
| Color Depth | Input: 8/10/12-bit, 8-bit (4K60Hz 4:4:4) Output: 8-bit |
| Color Space | RGB, YCbCr 4:4:4 / 4:2:2. YUV 4:2:0 |
| Transmission Distance | 100M (CAT6/6A/7) |
| Audio Formats | LPCM 2.0/5.1/7.1CH, Dolby Digital/Plus/EX, Dolby True HD, Dolby Atmos, DTS, DTS-96/24, DTS-EX DSD, DTS High Res, DTS-HD Master, DTS:X |

| | | |
|--|---|----------------------------------|
| Analog Input/ Output Audio Parameters | Input/Output Impedance | >=10k ohms/330 ohms |
| | Line Input/Output Level (Maximum) | 1Vrms/1Vrms |
| | Frequency Response | (+0.5dB, -1dB) 20Hz ~ 20kHz |
| | Audio Output Sync Delay | TBD |
| | Audio S/N Ratio | >90dB@ HDMI 0dB, 1kHz A-weighted |
| | Audio THD+N | <0.05%@ HDMI 0dB, 1KHz |
| ESD Protection | IEC 61000-4-2: ±15kV (Air-gap discharge) & ±8kV (Contact discharge) | |
| Connection | | |
| Encoder | Input: 1x HDMI IN [HDMI Type A, 19-pin female] 2x USB-C IN [USB Type C, 24-pin female] 1x AUDIO IN [3pin-3.5mm Phoenix connector] Output: 1x AUDIO OUT [3pin-3.5mm Phoenix connector] Control: 1x RS-232 [3pin-3.5mm Phoenix connector] 1x LAN (PoE) [RJ45 jack] 1x USB 2.0 HOST [USB Type B, 4-pin female] 2x USB 2.0 DEVICE [USB Type-A, 4-pin female] | |
| Decoder (Can work with any decoder of the same series) | Input: 1x SPDIF IN [Optical audio connector] 1x L/R AUDIO IN [3-pin 3.81mm Phoenix connector] Output: 1x HDMI OUT [Type A, 19-pin female] 1x L/R AUDIO OUT [3-pin 3.81mm Phoenix connector] Control: 1x RS-232 [3.81mm Phoenix connector] 1x LAN (POE) [RJ45 jack] 1x FIBER [Optical fiber slot] 2x USB 1.1 DEVICE [Type-A, 4-pin female] 2x USB 2.0 DEVICE [Type-A, 4-pin female] 2x RELAYS [3.81mm Phoenix connector] 2x DIGITAL IO [3.81mm Phoenix connector] 1x IR IN [3.5mm audio Jack] 1x IR OUT [3.5mm audio Jack] | |

| Mechanical | | | |
|---|---|-------------|----------------|
| Housing | Encoder: Aluminum panel + Iron case Decoder: Metal enclosure | | |
| Color | Encoder: White panel + Black case Decoder: Black | | |
| Dimensions | Encoder: 115.9mm [W] x 114.3mm [H] x 44.25mm [D] Decoder: 204mm [W] x 136mm [D] x 25.5mm [H] | | |
| Weight | Encoder: 350g Decoder: 626g | | |
| Power Supply | Input: AC100 - 240V 50/60Hz, Output: DC 12V/2.5A (US/EU standards, CE/FCC/UL certified) | | |
| Power Consumption | Encoder: 12W (Max.) Decoder: 7.08W (Max.) | | |
| Operating Temperature | 32 - 104°F / 0 - 40°C | | |
| Storage Temperature | -4 - 140°F / -20 - 60°C | | |
| Operating Humidity | 20% - 80% (relative humidity, no condensing) | | |
| Storage Humidity | 10% - 90% (relative humidity, no condensing) | | |
| Video Resolution | 4K60 | 4K30 | 1080P60 |
| HDMI Cable Length (HDMI IN/OUT) | 16ft/5M | 32ft/10M | 50ft/15M |
| The use of "Premium High Speed HDMI" cable is highly recommended. | | | |

5. Operation Controls and Functions

5.1 Encoder Panel

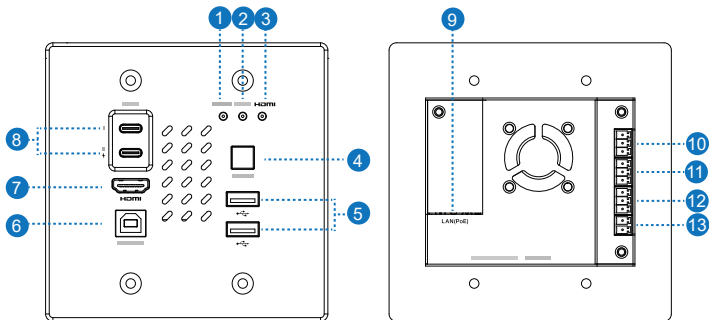

| No. | Name | Function Description |
|-----|--------------------|--|
| 1 | STATUS LED (Green) | Connection status indicator light. <ul style="list-style-type: none">Light on: Encoder and Decoder are connected through the LAN(PoE) port, and there is video signal transmitted to the Decoder.Light flashes: Encoder and Decoder are connected through the LAN(PoE) port, but there is no video signal transmitted to the Decoder.Light off: Encoder and Decoder are not connected through the LAN(PoE) port. |
| 2 | USB-C LED (Green) | USB-C input status indicator light. <ul style="list-style-type: none">Light flashes: The USB-C port is selected as the signal input channel, and the signal source device is connected, but there is no video signal input.Light on: The USB-C port is selected as the signal input channel, the signal source device is connected, and there is video signal input. |
| 3 | HDMI LED (Green) | HDMI input status indicator light. <ul style="list-style-type: none">Light flashes: The HDMI port is selected as the signal input channel, and the signal source device is connected, but there is no video signal input.Light on: The HDMI port is selected as the signal input channel, the signal source device is connected, and there is video signal input. |

| No. | Name | Function Description |
|-----|----------------|---|
| 4 | SOURCE button | <ul style="list-style-type: none"> ▪ Short press to switch the input signal source (HDMI/USB-C) ▪ Press and hold the button for 5 seconds to restore the unit to factory default settings (The STATUS, USB-C and HDMI LEDs will simultaneously light off/on, quickly flash 3 times to indicate the resetting). <p><i>Note: The USB-C 1 port and HDMI port support auto signal detection and switching as default.</i></p> |
| 5 | USB-A port | Two USB 2.0 DEVICE ports, connected to USB 2.0 devices. For local DC power supply, the output power of this port is 5V/0.6A; For PoE power supply, the output power is 5V/0.2A. |
| 6 | USB-B port | USB 2.0 HOST port, connected to PC. For the HOST of USB-B /USB-C port, users can select AUTO (default) /USB-B/USB-C via API commands. |
| 7 | HDMI port | HDMI signal input port, supporting 4K60 4:4:4/HDR. Connect to an HDMI source device such as Blu-ray Player or Set-top box with an HDMI cable |
| 8 | USB-C 1/2 port | <p>USB-C 1 port: Support 4K60 audio/video and USB 2.0 signals transmission, and charging the external device (The USB-C 2 port must be connected to the power supply).</p> <p>USB-C 2 port: USB-C power input port, only supporting USB Type C PD power input. Connect this port to the UCB-C power adapter to charge the device connected to the USB-C 1 port.</p> |
| 9 | LAN(PoE) port | 1G network port, supporting PoE power supply from the Switch, adaptive PoE or PoE+. |
| 10 | AUDIO IN port | Analog audio input port, used for analog audio embedding, supporting unbalanced audio input, with a maximum support of 1Vrms. Unbalanced connection method: L-, GND, R- |
| 11 | AUDIO OUT port | Analog audio output port, used to output the PCM audio de-embedded from the HDMI input (default), or loop output the embedded audio from the AUDIO IN port, supporting unbalanced audio output, with a maximum support of 1Vrms. Unbalanced connection method: L-, GND, R- |
| 12 | RS-232 port | RS-232 serial port, connected to PC or control system for RS-232 signal pass-through or local serial port control. |
| 13 | DC 12V port | <p>The device can be powered via two methods:</p> <ul style="list-style-type: none"> ▪ Local DC 12V/2.5A power supply (with the priority) ▪ PoE from the Network Switch. Device acts as PD mode. When the Switch supports PoE function, DC power supply is not needed. <p><i>Note: When USB device ports connect heavy power load devices, DC power supply is preferred.</i></p> |

5.2 Decoder Panel

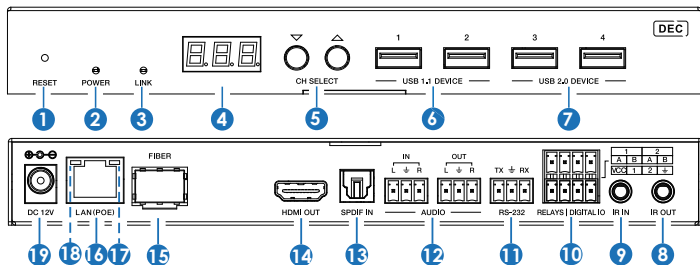

| No. | Name | Function Description |
|-----|------------------|---|
| 1 | RESET | After powering on the device, press and hold the RESET button until the POWER LED and LINK LED flash at the same time, release the button to reset the device to factory settings. |
| 2 | POWER LED (Red) | <ul style="list-style-type: none"> Light on: The system is powered on (with PoE or DC power supply). Light off: The system is powered off (without PoE or DC power supply). |
| 3 | LINK LED (Green) | <p>Connection status LED.</p> <ul style="list-style-type: none"> Light on: Encoder and Decoder are connected through the LAN(POE) port, and there is video signal transmitted from the Encoder. Light flashes: Encoder and Decoder are connected through the LAN(POE) port, but there is no video signal transmitted from the Encoder. Light off: Encoder and Decoder are not connected through the LAN(POE) port. |
| 4 | LED screen | Shows the selected Encoder ID as default. Displays the corresponding options of configuration functions during setting Decoder configurations. |
| 5 | CH SELECT | Used to set Decoder ID and other settings. |
| 6 | USB 1.1 DEVICE | Connect to USB 1.1 devices, such as Keyboard or Mouse. |
| 7 | USB 2.0 DEVICE | Connect to USB 2.0 devices, such as USB flash disk or USB Camera. |
| 8 | IR OUT | IR signal output port. The IR level can be set to 5V or 12V (default) through the panel buttons. |
| 9 | IR IN | IR signal input port. The IR level can be set to 5V or 12V (default) through the panel buttons. |

| No. | Name | Function Description |
|-----|-------------------------------------|---|
| 10 | RELAYS I DIGITAL IO | <p>VCC: Power output (12V or 5V configurable), maximum to 12V @50mA, 5V@ 100mA loading. The default output is 12V.</p> <p>RELAYS: 2 channel low-voltage relay ports, each group is independent and isolated, maximum to 1A 30VDC loading. Contacts are disconnected by default.</p> <p>DIGITAL IO: 2 channel GPIO ports, for digital level signal output control or input detection (up to 12V level detection). The output control mode (default mode, low level as default output) or input detection mode is configurable. The DIGITAL IO internal pull-up voltage follows the VCC.</p> <p>Output control mode:</p> <ol style="list-style-type: none"> The maximum withstand sink current is 50mA when outputting low level. When VCC is 5V and high level is output, the maximum current driving capacity is 2mA. When VCC is 12V and high level is output, the maximum current driving capacity is 5mA. <p>Input detection mode:</p> <ol style="list-style-type: none"> When VCC is 5V, DIGITAL IO is pulled up to 5V internally through a 2.2K ohm resistor. When VCC is 12V, DIGITAL IO is pulled up to 12V internally through a 2.2K ohm resistor. |
| 11 | RS-232 | RS-232 serial port, supporting RS-232 command pass-through and local serial port control. |
| 12 | AUDIO IN/OUT | <p>AUDIO IN: Analog audio input port, the audio can be transmitted to Encoder AUDIO OUT in unicast mode (point-to-point direct connection).</p> <p>AUDIO OUT: Analog audio output port. It outputs the same audio of that on HDMI OUT in case audio format is LPCM.</p> |
| 13 | SPDIF IN | S/PDIF signal input port. |
| 14 | HDMI OUT | HDMI signal output port, connected to an HDMI display device such as TV or monitor. |
| 15 | FIBER | Connect with optical fiber module, and receive signals from the Encoder with an optical fiber cable directly or through a Switch. |
| 16 | LAN (POE) | <p>1G LAN port, connect network Switch to form a distributed system.</p> <p><i>Note: When network switch delivers PoE power supply, DC 12V adapter doesn't need to apply on the unit.</i></p> |
| 17 | Data Signal Indicator lamp (Yellow) | <ul style="list-style-type: none"> Light flashing: There is data transmission. Light off: There is no data transmission. |

| No. | Name | Function Description |
|-----|------------------------------------|---|
| 18 | Link Signal Indicator lamp (Green) | <ul style="list-style-type: none"> Light on: The network cable is connected normally. Light off: The network cable is not connected well. |
| 19 | DC 12V | <p>The device can be powered via two methods:</p> <ul style="list-style-type: none"> Local DC 12V/2.5A power supply PoE from the Network Switch. Device acts as PD mode. <p>When the Switch supports PoE function, DC power supply is not needed.</p> |

6. MJPEG Substream Operation Introduction

6.1 MJPEG Substream Preview/Configuration via Web Page

The product supports playing MJPEG Substream on computer through the corresponding software such as **VLC media player**, simultaneously you can access the Web page to configure the MJPEG Substream.

Follow the steps below to preview and configure the MJPEG Substream.

Step 1: Connect the Encoder, Decoder and PC to the same Switch, then connect an HDMI source device and power supply. The connection diagram is shown as below.

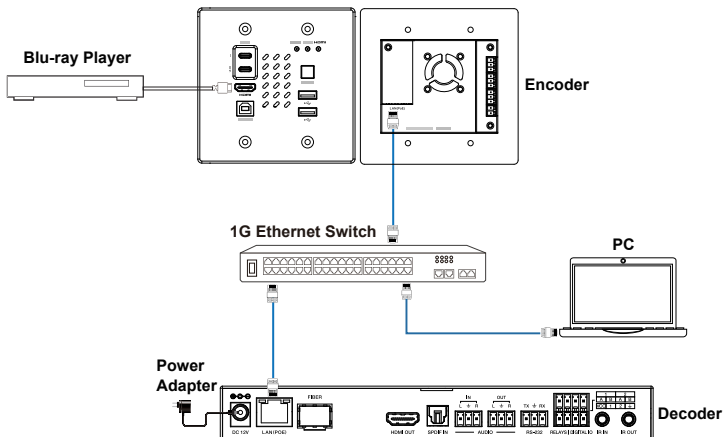

Step 2: Install a Bonjour protocol checking tool (such as zeroconfService Browser) on PC to find the IP address of the Encoder/Decoder. Take zeroconfServiceBrowser as an example. After opening the software, you can select “Workgroup Manager” in Services of Browser, select the Host name in Service-Instances, and find the IP address in the Address item in of Instance-Info.

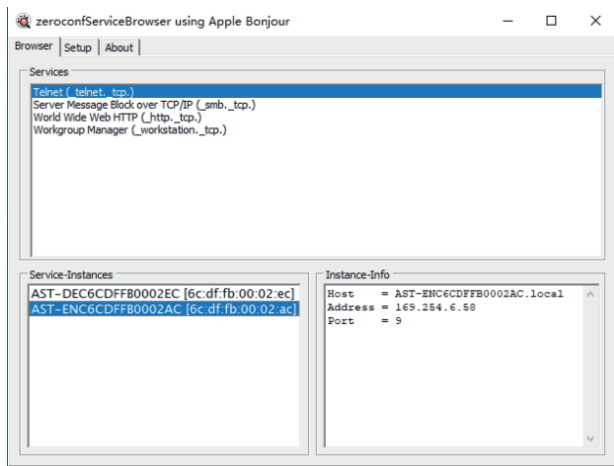

Note:

- (1) The window in the lower left corner displays the Host names of all devices in the current network.*
- (2) The window in the lower right corner displays the Host name, IP address and Port number of the device.*
- (3) The Host name of Encoder starts with AST-ENC; the Host name of Decoder starts with AST-DEC.*

Step 3: Set the PC's IP address to the same network segment with IP address of the Encoder/Decoder found in step 2.

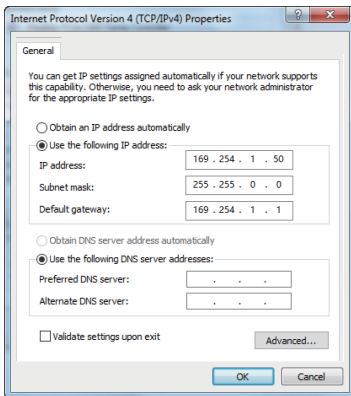
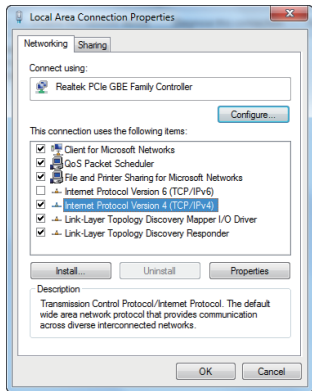

Step 4: According to the IP address of the Encoder/Decoder found through the Bonjour protocol checking tool, input “http://IP:PORT/?action=stream” into the web browser on PC. The MJPEG Substream will be displayed with the default resolution, as shown in the figure below.

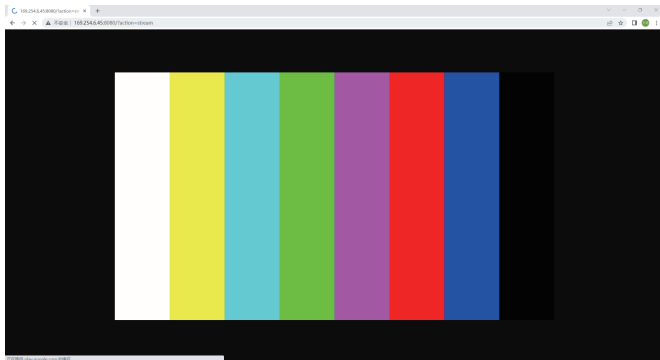

Step 5: Change the resolution of the obtained Encoder/Decoder IP address in the following format.

http://IP:PORT/?action=stream&w=x&h=x&fps=x&bw=x&as=x&mq=x

- **WIDTH:** [Optional] image width. In pixels. 'x' means no change.
Default is 640.
- **HEIGHT:** [Optional] image height. In pixels. 'x' means no change.
Default is 360.
- **FRAMERATE:** [Optional] frame rate of sub-stream.
Unit: fps (frame per second). 'x' means no change. Default is 30.
- **BW:** [Optional] maximum bandwidth of sub-stream traffic.
Unit: Kbps (Kbits per second). 'x' means no change. Default is 8000 (8Mbps).
- **AS:** [Optional] aspect ratio configuration. 'x' means no change. Default is 0.
- **0:** extend to what "WIDTH" and "HEIGHT" configured
- **1:** [A1 only] keep original aspect ratio and place in the center of output
(letterboxing or pillarboxing)
- **MINQ:** [Optional] minimum image quality number. Range: 10, 20, ..., 90, 100, higher setting means better image quality. 'x' means no change. Default value is 10. Limit driver auto bandwidth control's minimum quality number. If quality lower then MINQ value, the driver will drop frame by returning 0 size file.

After changing, input the new Encoder/Decoder IP address into the web browser on PC, the MJPEG Substream will be displayed with the desired resolution, as shown in the figure below.

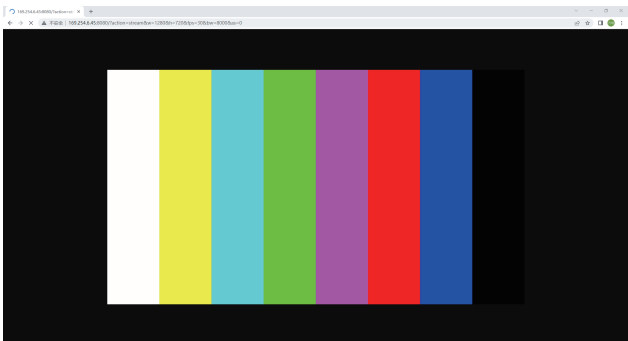

6.2 VLC Media Player Instruction

Firstly, perform the step 1~3 as described in Chapter 6.1, then open the VLC media player on PC. Please see the following icon.

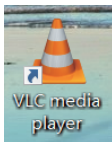

Click “Media > Open Network Stream”

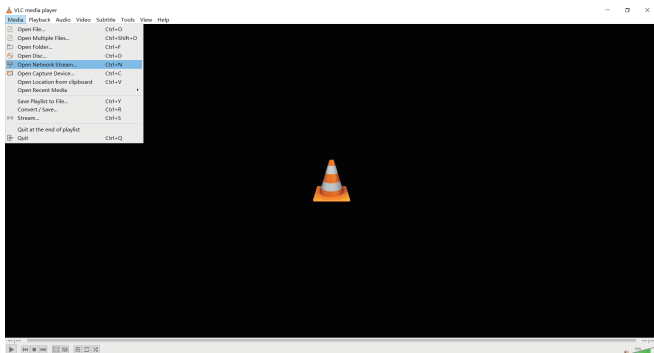

After clicking the “Open Network Stream” option, the following page will appear.

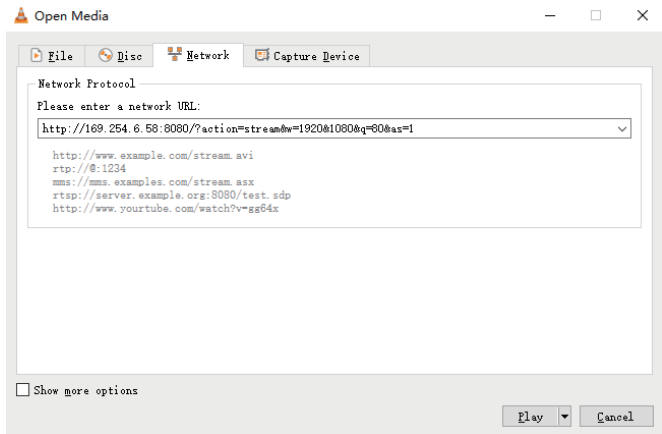

Enter the MJPEG Substream network URL, then click **“Play”** button.

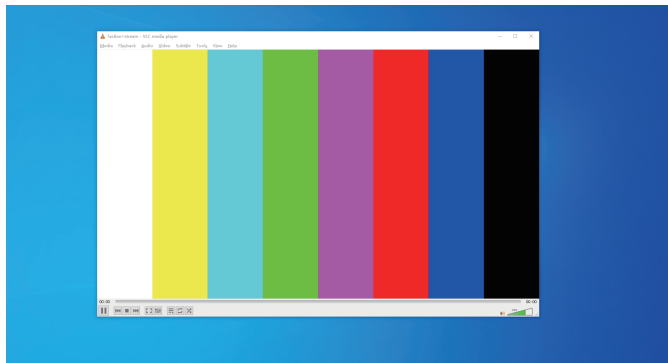

Choose **“Tools>Codec information”**, a pop-up window will display and show you Stream information, as shown in the figure below.

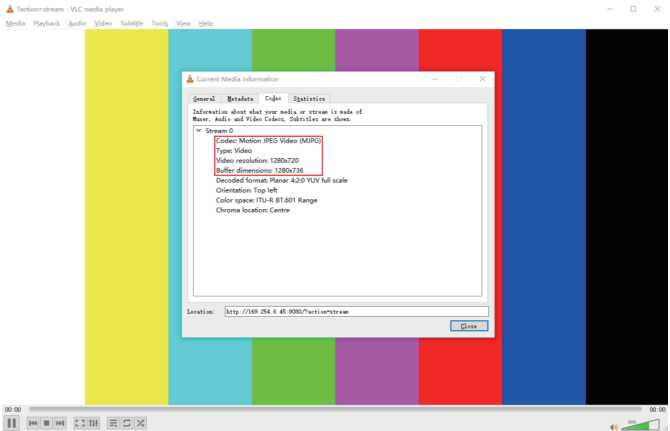

Choose **“Tools>Codec information>Statistics”** to check current Bitrate. Please see the following picture.

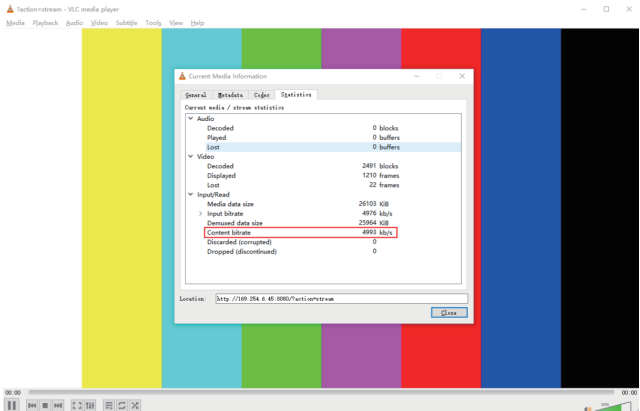

Note: The Bitrate is floating up and down when you check it. This is a normal phenomenon.

7. Switch Model

A network Switch used to set up the system should support below features:

1. Type of layer 3/managed network Switch.
2. Gigabit bandwidth.
3. 8KB jumbo frame capability.
4. IGMP snooping.

The following Switch models are highly recommended.

| Manufacturer | Model Number |
|---------------------|----------------------|
| CISCO | CISCO SG500 |
| CISCO | CATALYST series |
| HUAWEI | S5720S-28X-PWR-LI-AC |
| ZyXEL | GS2210 |
| LUXUL | AMS-4424P |

8. 4K over IP System Control

This product can be controlled by Controller Box or third-party controller. For details of 4K over IP system control, please refer to the user manual of “Video over IP Controller”.

9. Application Example

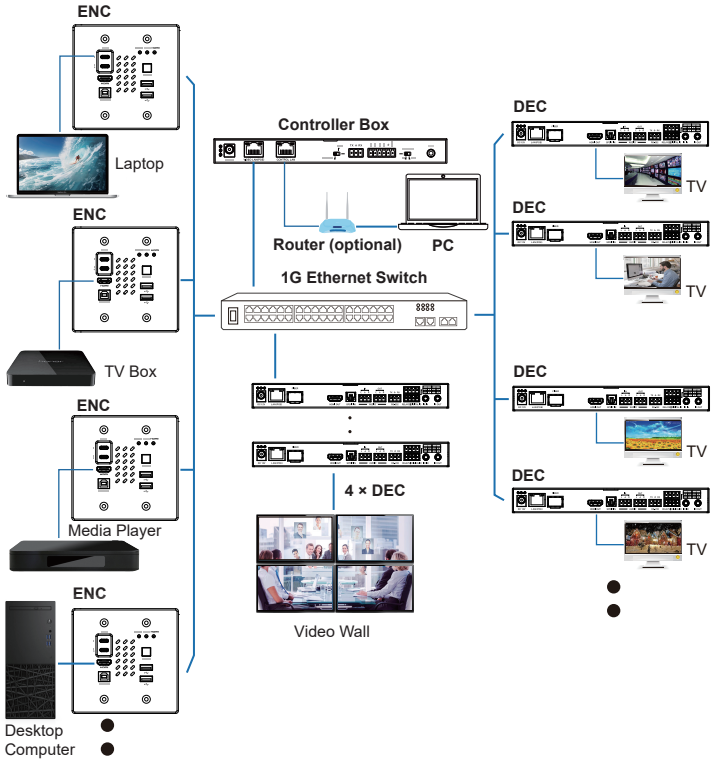

The terms HDMI and HDMI High-Definition Multimedia interface, and the HDMI Logo are trademarks or registered trademarks of HDMI Licensing LLC in the United States and other countries.

Notes:

(1) The Controller has two LAN ports, one is Video LAN and the other one is Control LAN. The purpose of designing Controller with two LAN ports is to isolate audio/video (AV) network from control network. So to make AV network as an independent network which can not be accessed from control network directly, it's for bringing network security and avoiding AV network traffic flowing into the network in which the controls and managements are for the IP system.

The strongly recommended system setup is connecting Video LAN and Encoders/Decoders in a network Switch, connecting Control LAN and PC in another network Switch. The controls from Control LAN can be achieved by Web GUI/Telnet or SSH login/API commands, all these controls can be bridged by the Controller and applied onto Video LAN. The two LANs are isolated.

For simple usage, you can only connect all Encoders/Decoders and Video LAN and PC RJ-45 port into a single network, and let the Control LAN port not-connected (floating), as Video LAN also supports Web GUI/Telnet or SSH login/API commands controls, this seems "convenient" for general use scenarios, but this is only suggested for system in which there is no network isolation requirement or network traffic non-sensitive.

Only Control LAN connected while Video LAN floating, this is not allowed.

(2) For the default IP mode of Control LAN port of the Controller Box is DHCP, the PC also needs to be set to "Obtain an IP address automatically" mode, and an optional DHCP server (e.g. network router) is recommended in the system.

(3) If there is no DHCP server in the system, 192.168.6.100 will be used as the IP address of Control LAN port. You need to set the IP address of the PC to be in the same network segment. For example, set PC's IP address as 192.168.6.88.

(4) You can access the Web GUI by inputting URL "http://controller.local" or the Control LAN port IP address 192.168.6.100 (in case of no optional router) on your computer's browser.

(5) No need to care about settings of Video LAN port of the Controller Box, as they are managed by Controller automatically (Default).

(6) When the Network Switch does not support PoE, the Encoder, Decoder and Controller Box should be powered by DC power adapter.